

SHOP MATERIAL LIST FOR 2 ASSEMBLIES					
MARK	SIZE	LENGTH MM	No	AREA M2	WEIGHT KG
001	COLUMN		2	1.23	50.0
	100X50X6.0RHS	3200	2	1.82	76.8
f001	90X10FLAT	200	2	0.08	2.8
f002	90X8FLAT	200	2	0.08	2.3
f003	45X5FLAT	95	2	0.02	0.3
f009	90X10FLAT	150	2	0.06	2.1
f013	250X12FLAT	250	2	0.27	11.8
f066	90X10FLAT	150	2	0.06	2.1
f090	75X10FLAT	155	2	0.06	1.8
TOTAL			2.47	100.1	

SURFACE TREATMENT:  
HOT DIP GALVANIZE  
AFTER FABRICATION

FINISHED FLOOR LEVEL IS 232 ABOVE USBP  
APPLY INTERZONE 954HS TO MINIMUM  
THICKNESS 400um.

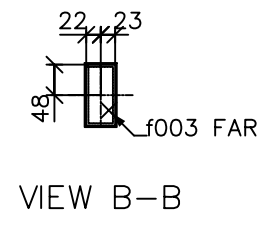
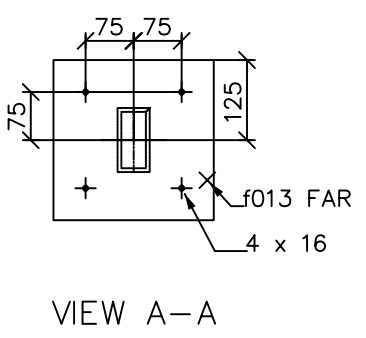
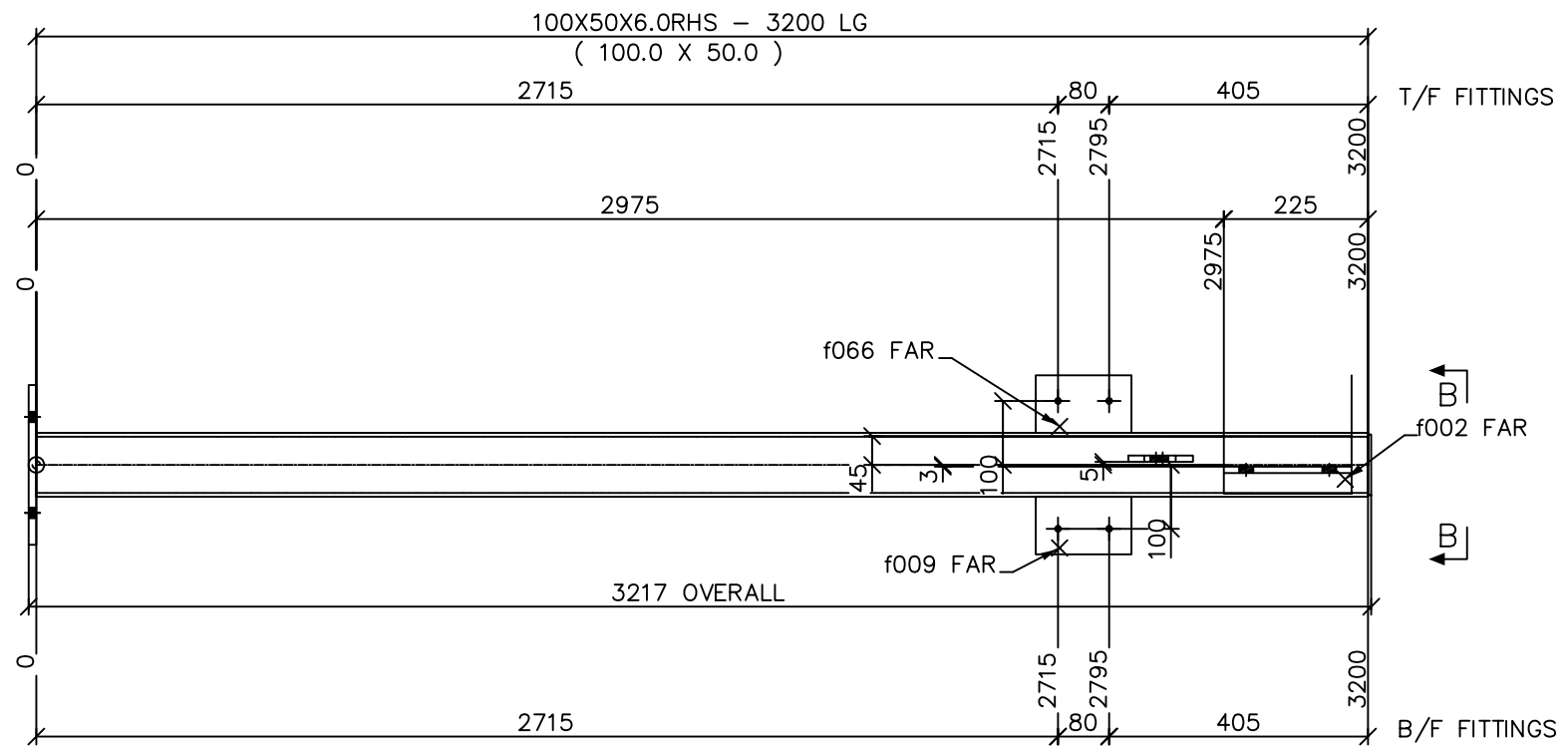

2 REQ'D AS DRAWN 001

STRUCAD

**INFO DRAFT AUSTRALIA**  
3D STRUCTURAL STEEL DETAILING  
UNIT 3/2 - MULGUL ROAD - MALAGA - WA 6090  
PH : (08)9248 6519 FAX : (08)9248 7196

CLIENT: XXXX				
PROJECT: CAREY BAPTIST COLLEGE STAGE 7 SCIENCE BLOCK				
REV	SCALE	JOB NUMBER	MEMBER	DRAWING NUMBER
0	NTS	XXXX	COLUMN	001

DRAWN BY: DATE: